

LED T8 - OPEN COMMERCIAL

KDS100 SERIES

Knocked Down One Light Strip

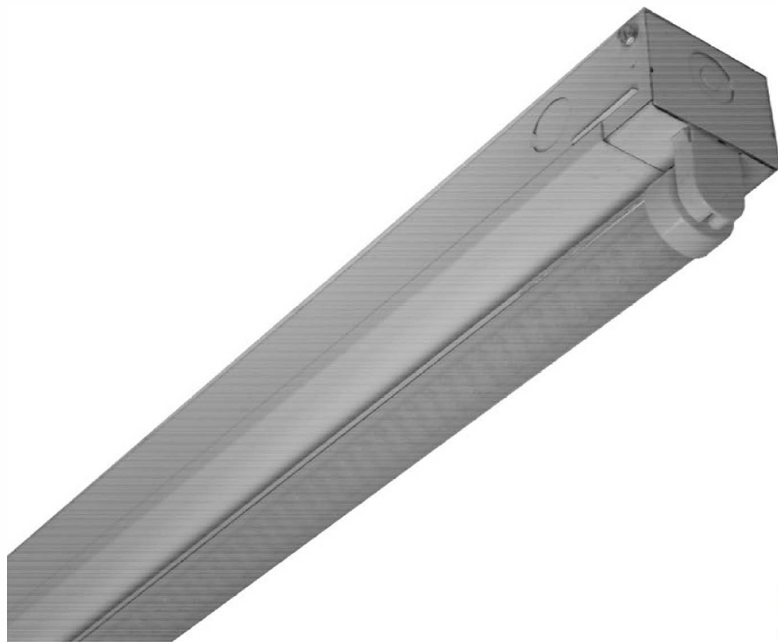

- Knocked Down 1-Lamp Strip For LED T8 Internal Driver Light Tube (by Others)
- 22 Gauge Cold Rolled Steel Housing
- Screw-On End Caps
- Cover Secured by Two Quarter Turn Fasteners

• Available with:

Heavy Duty Safety Switch



LOS ANGELES LIGHTING MFG. CO.

10141 OLNEY ST. / EL MONTE, CA 91731

<http://www.lalighting.com>

TEL : 626-454-8300 FAX : 626-454-8399

KDS100-1-4L-LED8

TEST NO.=LA-T1782-1
LAMP TYPE=LED T8, 4'
NO. OF LAMP=1
LUMENS PER LAMP=1300
WATTSPER LAMP=15
BALLAST FACTOR=1
PHOTOMETRY TYPE=C

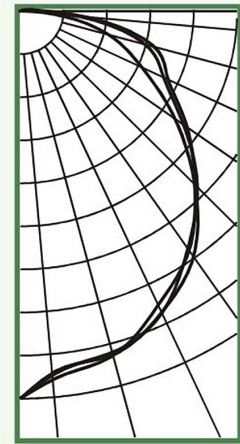

CANDLEPOWER

Angle	End	45	Cross
0	426	426	426
5	400	402	407
15	391	389	382
25	365	366	357
35	330	319	321
45	369	274	269
55	206	218	223
65	147	173	178
75	100	141	152
85	35	62	71
90	6	20	28
95	2	11	16
105	0	3	5
115	0	0	2
125	0	0	0
135	0	0	0
145	0	0	0
155	0	0	0
165	0	0	0
175	0	0	0
180	0	0	0

ZONAL LUMEN SUMMARY

DEGREES	LUMENS	% LAMP	% FIXTURE
0-30	317	24.4	24.4
0-40	520	40.0	40.0
0-60	924	71.1	71.1
0-90	1284	98.8	98.8
90-120	16	1.2	1.2
90-150	16	1.2	1.2
90-180	16	1.2	1.2
0-180	1300	100.0	100.0

Luminaire Efficiency = 100.0%

SPACING CRITERION

ALONG	ACROSS
1.21	1.19

LED T8 - OPEN COMMERCIAL

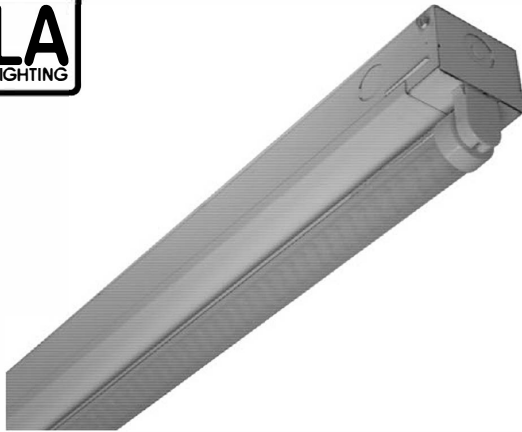

KDS100 SERIES - LED T8

CROSS SECTION

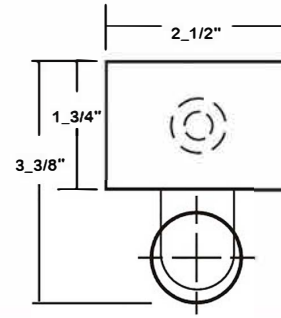

BACK PLATE

- 3/16" MTG. HOLE
- 7/8" K.O.
- V-HOOK

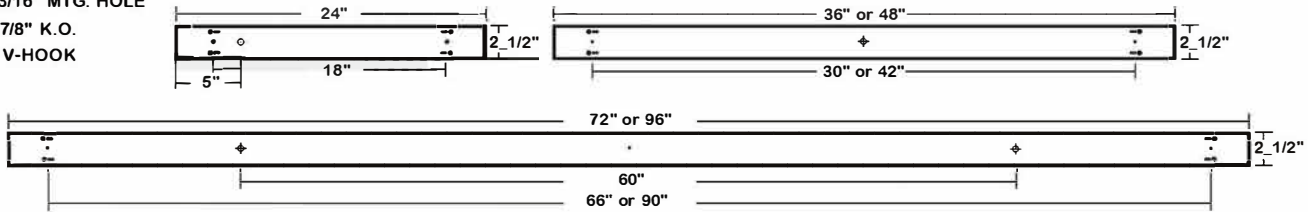

CATALOG NUMBER

NOMINAL LENGTH	TOTAL LAMPS		NOMINAL LENGTH	TOTAL LAMPS	
KDS100-1-2LI	2'	1	KDS100-1-4LI	4'	1
KDS100-1-2LR	2'	1	KDS100-1-4LR	4'	1
KDS100-1-2LO	2'	1	KDS100-1-4LO	4'	1
KDS100-1-3LI	3'	1	KDS100-1-6LIT	6'	2
KDS100-1-3LR	3'	1	KDS100-1-6LRT	6'	2
KDS100-1-3LO	3'	1	KDS100-1-6LOT	6'	2
			KDS100-1-8LIT	8'	2
			KDS100-1-8LRT	8'	2
			KDS100-1-8LOT	8'	2

SAFETY SWITCH



TS2 - LED Luminaire On/Off Safety Switch

- Easily accessible on exterior of wire way.
- Allows individual fixture to be switched ON/OFF during re-lamping or Maintenance.
- Prevents damage to lamp and electrical shock during lamping and re-lamping.
- Allows safe entry to wire way channel where power connector can be disconnected for maintenance to fixture.

ORDERING GUIDE

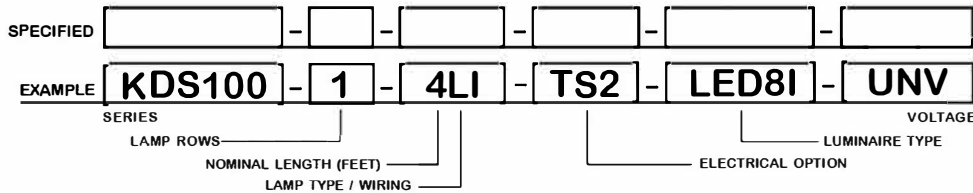

LAMP TYPE

LI = LED T8 internal driver light tube.

- Both ends powered.
- Shunted sockets used.



LR = LED T8 internal driver light tube.

- Single end powered.
- Non-shunted sockets used.



LO = LED T8 internal driver light tube.

- Both ends powered, one wire connects lampholders together from each side.
- Non-shunted sockets used.

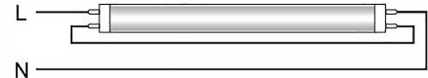

OPTIONS AND ACCESSORIES

ELECTRICAL OPTIONS

LED Luminaire ON/OFF Safety Switch

SUFFIX

TS2

ACCESSORIES

Wire Guard-14 Ga.

CAT. NO.

WG14-KDS100

*See Appropriate Reference Page

SPECIFICATIONS

** Lamp(s) by others.

- **TYPE** Knocked down open lamp one-light channel for LED T8 internal driver light tube (s)**.
- **CONSTRUCTION** 22 ga. cold rolled steel housing. End plates are fastened to housing by sheet metal screws to assure rigidity. End plates may be used as channel couplings.
- **FINISH** Baked white polyester finish standard, minimum reflectance 86%.
- **WIRE GUARD** Chrome epoxy powder coated.
- **WIRING** Operates LED T8 internal driver light tube(s)**.
- **LABELS** U.L. Listed. Suitable for damp locations.

